

Einsatzbereich: - 623 Isolierkörper 12/17-polig

TE Teile Nr.: 61-0172-080-000
IC Ref. Nr.: 61.172.80

Elektrische Werte

Bemessungsstrom max. 5 A*
Durchgangswiderstand < 5 mOhm

Werkstoff

Kontakt Federbronze,
aktiver Bereich vergoldet

Anschluss

Anschlussart/-bereich offener Crimp
Crimpgröße 3 (0,20 - 0,52 mm²)
max. Litzenaußendurchmesser ø1,6 mm
Abisolierlänge 2,7 mm

Mechanische Werte

Steckzyklen 500

Werkzeuge (nicht im Lieferumfang enthalten)

Handcrimpzange TE Teile Nr.: C0-0078-000-000
IC Ref. Nr.: C0.078.00

Crimpmaschine TE Teile Nr.: WA-1043-000-000
IC Ref. Nr.: WA10043

Crimpeinsatz für Maschine TE Teile Nr.: WM-1243-000-000
IC Ref. Nr.: WM10243

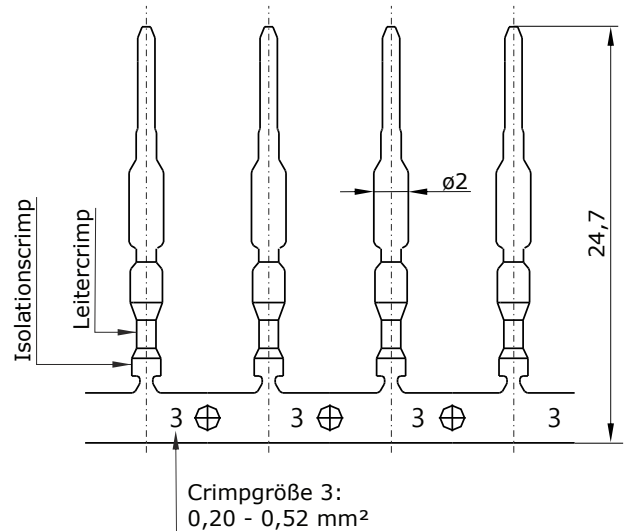

Hauptabmessungen

Kontaktstift





for: - 623 Insulation Inserts 12/17-pin

TE part number: 61-0172-080-000
IC reference number: 61.172.80

Electrical Data

rated current max. 5 A*
contact resistance < 5 mOhm

Material

contact phosphorus bronze,
active area gold plated

Termination

cross-section open crimp
crimp size 3 (0.20 - 0.52 mm²)
max. outer wire diameter $\varnothing 1.6$ mm
stripping length 2.7 mm

Mechanical Data

mating cycles 500

Tools (not part of product contents)

hand crimping tool TE part no.: C0-0078-000-000
IC ref. no.: C0.078.00

crimping machine TE part no.: WA-1043-000-000
IC ref. no.: WA10043

insert for crimping machine TE part no.: WM-1243-000-000
IC ref. no.: WM10243

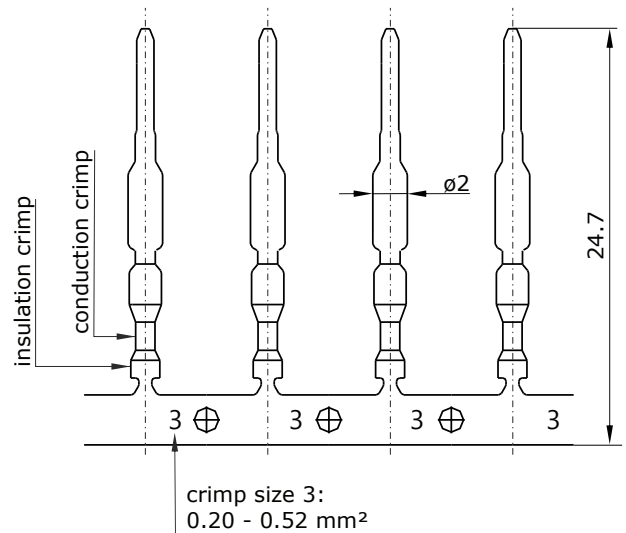

Main Dimensions

contact pin

© 2019 TE Connectivity

TE Connectivity, TE connectivity (logo), intercontec (logo) and speedtec are trademarks.

While TE Connectivity (TE) has made every reasonable effort to ensure the accuracy of the information in this presentation, TE does not guarantee that it is error-free, nor does TE make any other representation, warranty or guarantee that the information is accurate, correct, reliable or current. TE reserves the right to make any adjustments to the information contained herein at any time without notice. TE expressly disclaims all implied warranties regarding the information contained herein, including, but not limited to, any implied warranties of merchantability or fitness for a particular purpose. The dimensions in this article are for reference purposes only and are subject to change without notice. Specifications are subject to change without notice. Consult TE for the latest dimensions and design specifications.

