

LINEAR ACTUATOR

LD3 series

12/24V DC Motor
 Max. Load: 1200N
 Max. Speed: 45mm/sec
 Compact and Powerful

Feature :

Aluminum Extension & Outer Tubes
 Clevis to Clevis Mounting
 Stroke: 50, 100, 150, 200, 250, 300mm
 Duty Cycle: 25%
 Environment: -26°C~65°C
 Preset Limit Switches
 Gear Ratio: 5:1, 10:1, 20:1, 30:1, 40:1
 IP54

Option :

Hall Effect Sensor
 Potentiometer
 Optional or Customized Front
 Mounting Bracket
 Clamp
 IP65



Standard

Potentiometer

Hall Effect

| Standard | Stroke | 50 | 100 | 150 | 200 | 250 | 300 |
|----------|--------|-----|-----|-----|-----|-----|-----|
| | | A | 158 | 209 | 260 | 311 | 362 |
| | B | 208 | 309 | 410 | 511 | 612 | 713 |

A: Retracted Length
 B: Extended Length
 Stroke = B - A

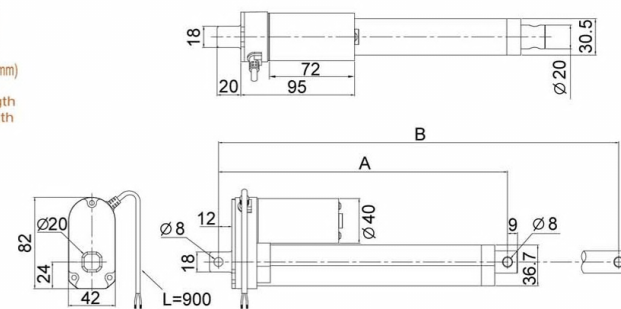

| Potentiometer | Stroke | 50 | 100 | 150 | 200 | 250 | 300 |
|---------------|--------|-----|-----|-----|-----|-----|-----|
| | | A | 195 | 246 | 297 | 348 | 399 |
| | B | 245 | 346 | 447 | 548 | 649 | 750 |

A: Retracted Length
 B: Extended Length
 Stroke = B - A

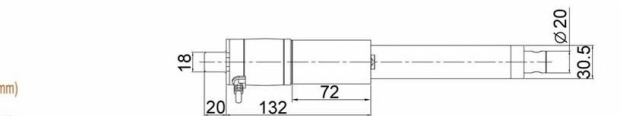

| Stroke(mm) | Resistance (Ω) |
|------------|----------------|
| 50 | 0.3-9.3K |
| 100 | 0.3-9.7K |
| 150 | 0.3-8.6K |
| 200 | 0.3-9.6K |
| 250 | 0.3-9.3K |
| 300 | 0.3-9.3K |

Remark: tolerance: ±0.3K

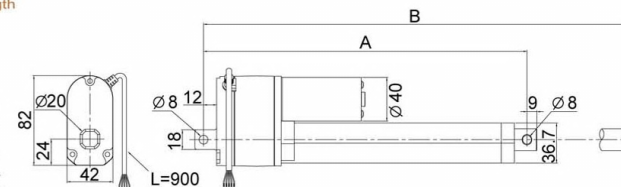
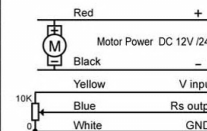

| Hall Effect | Stroke | 50 | 100 | 150 | 200 | 250 | 300 |
|-------------|--------|-----|-----|-----|-----|-----|-----|
| | | A | 158 | 209 | 260 | 311 | 362 |
| | B | 208 | 309 | 410 | 511 | 612 | 713 |

A: Retracted Length
 B: Extended Length
 Stroke = B - A

| Gear Ratio | Resolution(Pulses/mm) |
|------------|-----------------------|
| 5:1 | 2.3 |
| 10:1 | 3.6 |
| 20:1 | 6.9 |
| 30:1 | 10.6 |
| 40:1 | 14.3 |

Standard Plug for Hall Sensor Version

*Pin Data2 for 2 Hall Sensor Only

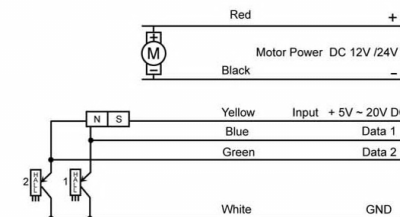
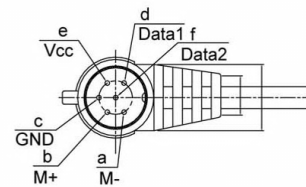

Front Connector

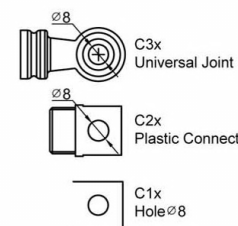

Model No. Designations:

| | |
|-------------------------|---------------------------------|
| D3 · 12 · 20 · 200 · HS | |
| Voltage | Option |
| 12-12V DC | 5-5:1 |
| 24-24V DC | 10-10:1 |
| | 20-20:1 |
| | 30-30:1 |
| | 40-40:1 |
| Gear Ratio | Stroke |
| 5-5:1 | 50mm(2") |
| 10-10:1 | 100mm(4") |
| 20-20:1 | 150mm(6") |
| 30-30:1 | 200mm(8") |
| 40-40:1 | 250mm(10") |
| | 300mm(12") |
| | Option |
| | HS: Hall Effect Sensor |
| | HS2: Dual Hall Effect Sensors |
| | POT: Potentiometer Sensor |
| | Clamp |
| | IP65 |
| | C2x |
| | C3x (C2x, C3x: Front Connector) |

Speed vs Load

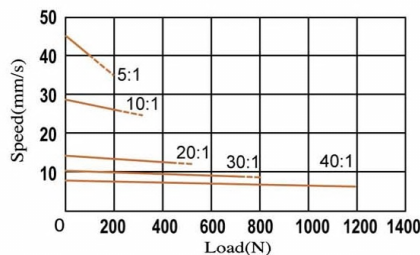

Current vs Load

